



DELIVERING YOUR MESSAGE

## PH20T

Plastic Directional Multi-purpose Horn Loudspeakers

### MAIN PROPERTIES

Rated power, Watts 20
Tappings 100 volt line, Watts 20/10/5/2.5
Transformer Impedance, Ohms, 100V 500/1k/2k/4k
Tappings 70.7 volt line, Watts 10/5/2.5/1.25
Driver impedance, Ohms 20
Effective frequency range, Hz (BSEN60268-5) 250-8,000
S.P.L. @ 1m, 1 watt, dB, Test Signal Bandwidth 100Hz-10 kHz 101
S.P.L. @ Full power, Octave Bandwidth, dB 114
Acoustic Power (dB-PWL@1 watt) 1 kHz, dB 98/98
Dispersion at 1k/2kHz, Degrees 130/70
Directivity Axial Q factor, 1 k/2kHz 4.9/13.6
Dimensions, front & depth, mm Ø203 x 254
Net weight, Kgs 1.7
Colour/Finish Grey RAL7035
Material ABS plastic housing with UV inhibitors
Mounting Stainless Steel U Bracket



# PH20T

Plastic Directional Multi-purpose Horn Loudspeakers

side view  
unit: mm

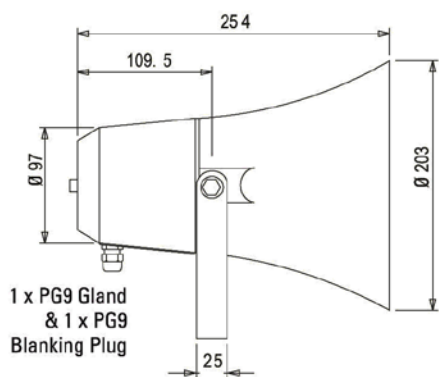

front view  
unit: mm

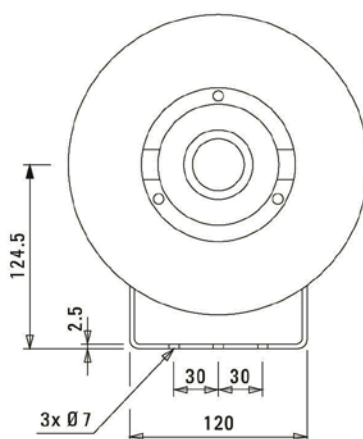

circuit diagram  
**PH20T**

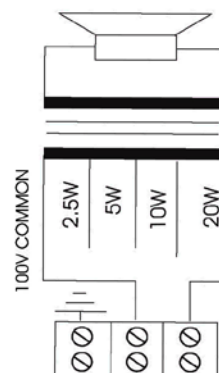

speech octave band sensitivity

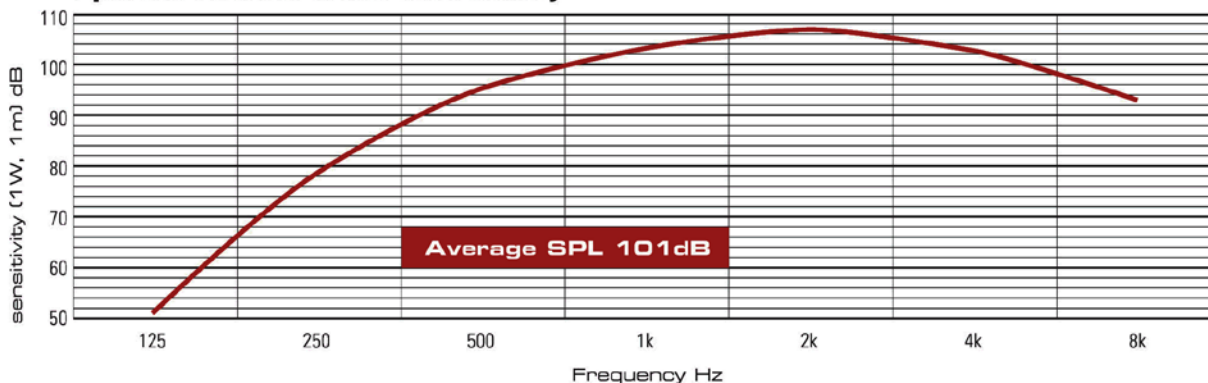

Effective Frequency Range **PH20T - PH20T/EN** 250Hz - 8,000Hz